

FOR METRI-PACK CABLE REFERENCE DS98546;
FOR DIN CABLE REFERENCE DS38082

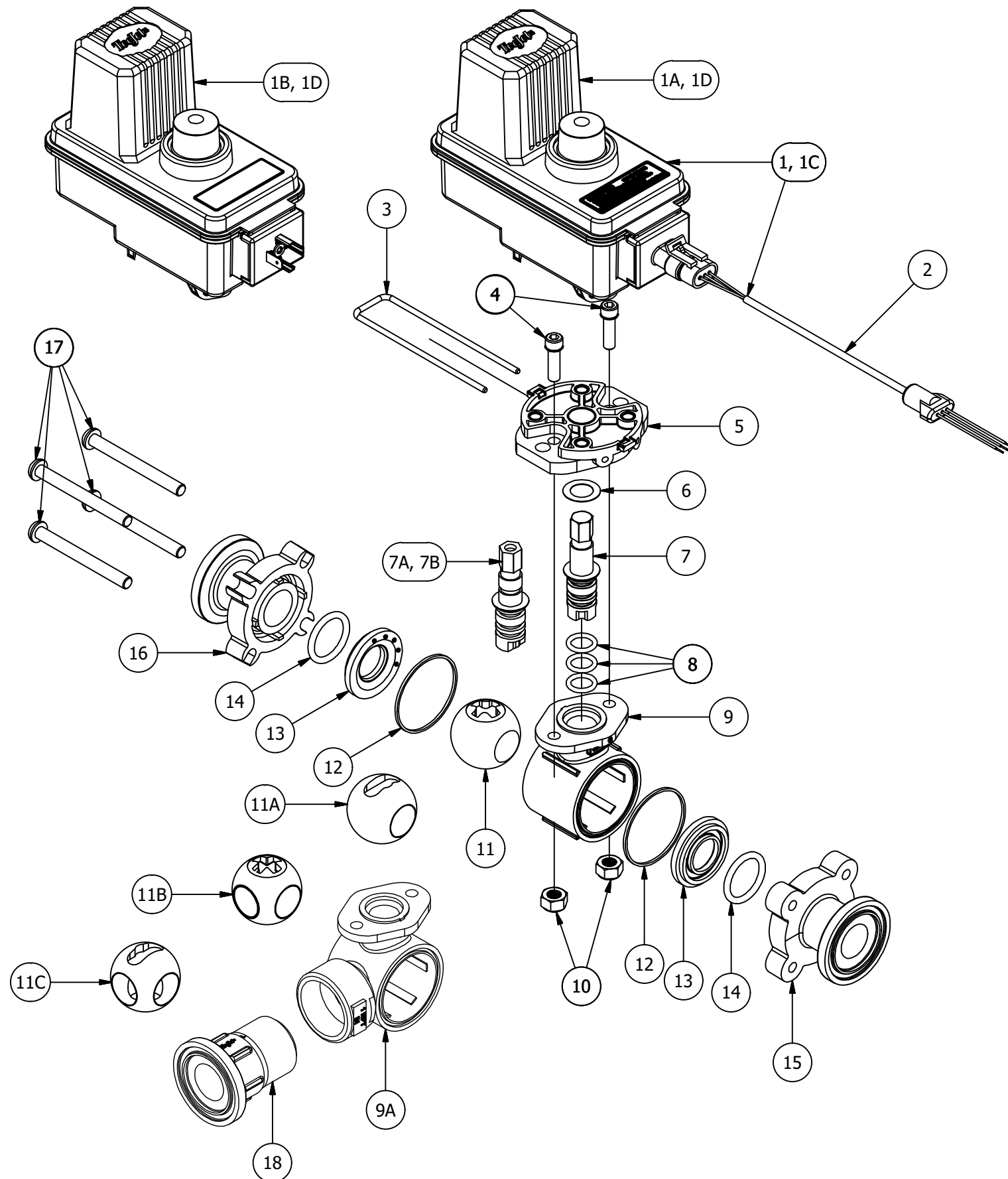

TEFLON® IS A TRADEMARK OF DUPONT COMPANY
VITON® IS A TRADEMARK OF DUPONT DOW ELASTOMERS

ITEM	PART NUMBER	DESCRIPTION
# 1	50515-22CP03	BEC MOTOR, 22-RPM (0.7-SEC), 0.3-METER CABLE, POSITIVELY SWITCHED
	50515-22CP05	BEC MOTOR, 22-RPM (0.7-SEC), 0.5-METER CABLE, POSITIVELY SWITCHED
	50515-22CP15	BEC MOTOR, 22-RPM (0.7-SEC), 1.5-METER CABLE, POSITIVELY SWITCHED
	50515-22CP60	BEC MOTOR, 22-RPM (0.7-SEC), 6.0-METER CABLE, POSITIVELY SWITCHED
# 1A	50515-22P	BEC MOTOR, 22-RPM (0.7-SEC), W/O CABLE, POSITIVELY SWITCHED
# 1B	50515-22DP	BEC MOTOR, 22-RPM (0.7-SEC), DIN CONNECTION, POSITIVELY SWITCHED
# 1C	50533-22C03	BE MOTOR, 22-RPM (0.7-SEC), 0.3-METER CABLE
	50533-22C05	BE MOTOR, 22-RPM (0.7-SEC), 0.5-METER CABLE
	50533-22C15	BE MOTOR, 22-RPM (0.7-SEC), 1.5-METER CABLE
	50533-22C60	BE MOTOR, 22-RPM (0.7-SEC), 6.0-METER CABLE
# 1D	50533-22P	BE MOTOR, 22-RPM (0.7-SEC), W/O CABLE
# 1E	50533-22DP	BE MOTOR, 22-RPM (0.7-SEC), DIN CONNECTION
2	98546EC-	3-WIRE CABLE W/ METRI-PACK TOWER CONNECTION
3	CP50517-SSPV	RETAINING CLIP, 304 STAINLESS STEEL
4	CP26197-7/8-SS	SOCKET HEAD CAP SCREW, STAINLESS STEEL (2 REQ'D)
5	CP50514-PP	MOTOR ADAPTER, POLYPROPYLENE (BLACK)
* 6	CP20125-TEF	THRUST WASHER, TEFLON
7	CP56613-SS	STEM, 303 STAINLESS STEEL (FOR POLYPROPYLENE BALL)
7A	CP56615-SS	STEM, 303 STAINLESS STEEL (FOR 2-WAY STAINLESS STEEL BALL)
7B	CP56614-SS	STEM, 303 STAINLESS STEEL (FOR 3-WAY STAINLESS STEEL BALL)
* 8	CP7717-M12X2.5-VI	O-RING, VITON (3 REQ'D)
9	CP20101-NYB	BODY, NYLON (BLACK) (2-WAY)
9A	CP20102-1-NYB	BODY, NYLON (BLACK) (3-WAY, 1" NPT THREAD)
10	CP38435-1/4-SSNY	ELASTIC LOCKNUT, STAINLESS STEEL (2 REQ'D)
11	CP20106-1-PP	BALL, POLYPROPYLENE (WHITE) (2-WAY)
11A	CP19926-SS	BALL, STAINLESS STEEL (2-WAY)
11B	CP20109-1-PP	BALL, POLYPROPYLENE (WHITE) (3-WAY)
11C	CP45510-1-SS	BALL, STAINLESS STEEL (3-WAY)
* 12	CP20564-VI	GASKET, VITON (2 REQ'D)
* 13	CP20103-TEF	SEAL, TEFLON (2 REQ'D)
* 14	CP7717-2/213-VI	O-RING, VITON (2 REQ'D)
15	CP48265-NYB	#50 FLANGED END CAP, NYLON (BLACK)
16	CP45253-NYB	#50 FLANGED END CAP, NYLON (BLACK)
17	CP45252-2-3/4-SSPV	PAN HEAD SCREW, STAINLESS STEEL (4 REQ'D)
18	CP48155-PP	#50 FLANGE X 1" MALE NPT FITTING, POLYPROPYLENE (BLACK)
19	56601-_-F-_-	FLANGED VALVE BODY SUB-ASS'Y, SPECIFY TYPE AND BALL MATERIAL, INCLUDES ITEMS 3-18; EXAMPLE: 56601-2-F-SS

AB344AE-KIT, SPARE PARTS KIT (INCLUDES ALL ITEMS MARKED WITH *)

#NOTE: FOR NEGATIVELY SWITCHED MOTORS SPECIFY "N" RATHER THAN "P" IN MOTOR PART NUMBER
EXAMPLE: 50515-22CN05

DESCRIPTION:
344BEC AND 344BE
DIRECTOVALVE®
FLANGED ELECTRIC
SHUT-OFF BALL VALVE



Spraying Systems Co.®
Spray Nozzles and Accessories
P.O. Box 7900 - Wheaton, IL 60189-7900

REVISION NO.	5
REFERENCE:	PARTS LIST PL344BEC-F
05/15/2019 SHEET:	DWG SIZE: B